

技术参数:

- 产品系列: M12 A-code
- 插针数: 5
- 额定电流(40℃): 4A
- 额定电压: 125V
- 额定脉冲电压: 1500V
- 污染等级: 3
- 接触电阻: ≤10mΩ
- 绝缘电阻: ≥100MΩ
- 锁紧方式: 螺纹式M12*1
- 电缆类型: PUR, 黑色RAL9005
- 线规: 0.25mm² (AWG24)
- 防护等级: IP67
- 插拔次数: >100
- 温度范围: -25℃ ... +85℃
- 锁紧螺帽: 金属
- 外壳材料: TPU
- 插体材料: PA
- 插针材料: 铜合金
- 插针电镀材料: 金

- Technical specification:
- Series: M12 A-Code
 - Number of contacts: 5
 - Rated current (40℃): 4A
 - Rated voltage: 125V
 - Rated impulse voltage: 1500V
 - Pollution degree: 3
 - Contact resistance: <10mΩ
 - Insulation resistance: ≥100MΩ
 - Connector locking system: screw M12*1
 - Cable type: PUR , Black RAL 9005
 - Wire gauge: 0.25mm² (AWG24)
 - Degree of protection: IP67
 - Mating cycles: >100
 - Temperature range: -25℃ ... +85℃
 - Material of locking system: Metal
 - Material of housing: TPU
 - Material of insert: PA
 - Material of contact: copper alloy
 - Contact plating: Au

插针数 Contacts	料号 Order No.	产品代号 Part Code	电缆长度(L) Cable length	重量 Weight
5	1630055024041	M12-F05A-S-1.5-PUR	1.5m	69g
	1630055024042	M12-F05A-S-5.0-PUR	5mm	197g

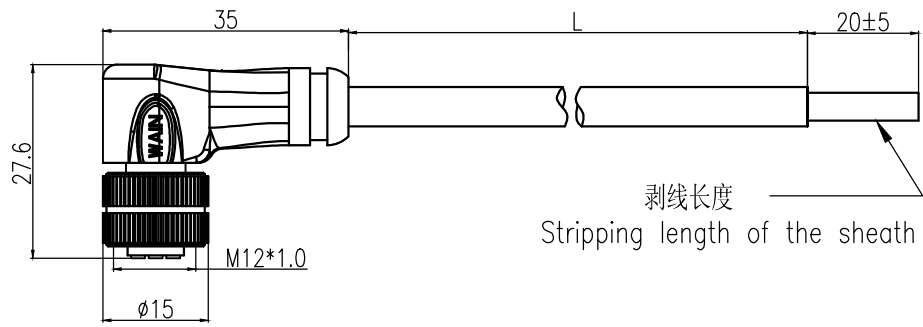

剥线长度
 Stripping length of the sheath

例如型号”M12-F05A-S-L-PUR”,
 ”L”表示带线长度, 单位m。
 Ex: Part code ”M12-F05A-S-L-PUR”,
 the ”L” represents the cable length, unit m.

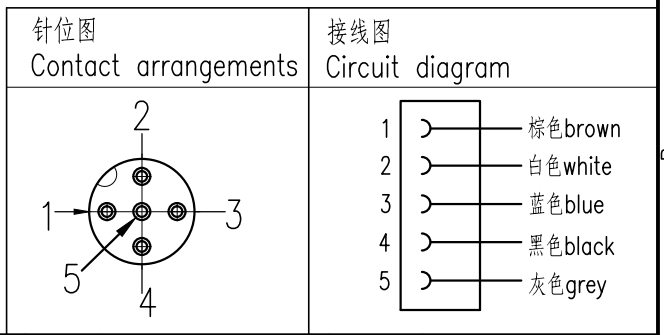

标记 Mark	处数 Number	变更描述/Description	签名 Signature	日期 Date	表面处理 Finish	材料 Material	图号 Drawing No.	
					-	-	-	
							产品代号 Part Code	
							M12-F05A-S-L-PUR	
							产品料号 Part No.	
							-	
							产品名称 Part Name	
							-	
绘图 Drawn	ZM LIN	18.03.2014	标准化 Stand.	-	-	-	-	
审核 Checked	YY LUO	18.03.2014						
工艺 Process	-	-	批准 Approved	YY LUO	18.03.2014			
					比例 Scale	版本 REV.	重量 Weight	数量 Qty.
					1:1	V1.0	-	-
							All Dimensions in mm Original Size DIN A 4	
							厦门唯恩电气有限公司 XIAMEN WAIN ELECTRICAL CO.LTD	